

1. Prendere la sedia (1) e richiudere i due fianchi inserendo la seduta (2) e richiuderla tutta in una volta come indicano le frecce;
2. Infine piegare leggermente il rinforzo centrale (3) incastrarlo nei fori appositi e poi spingere per rimetterlo dritto;
3. Risultato finale.

1

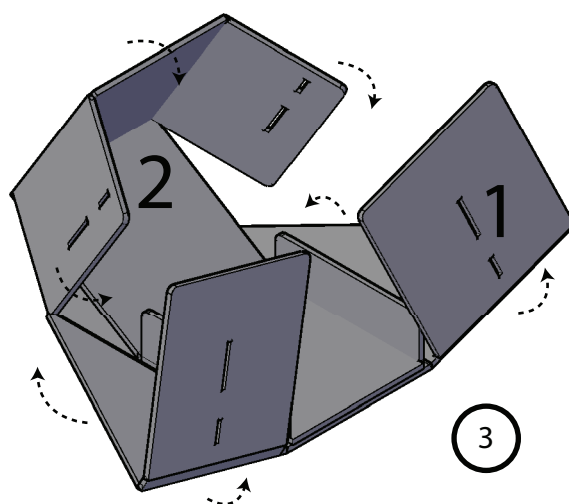

2

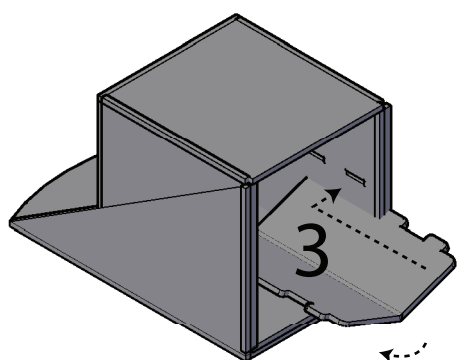

3

4

